

Q.FLAT-G6 S/EW

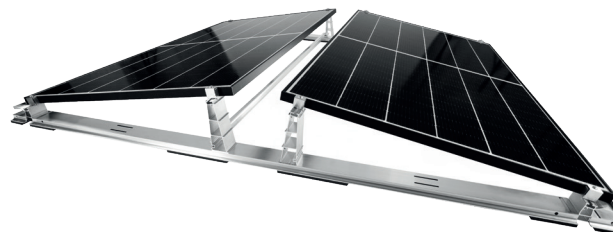

Flexible Flat-Roof Solar Module Mounting System For South or Two-Sided Orientation

MODEL Q.FLAT-G6 S/EW

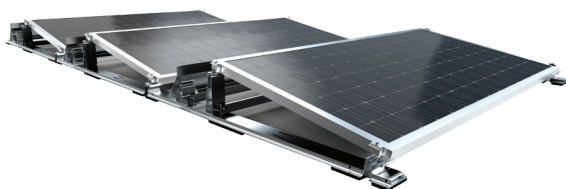

Maximum yields

Highest yields with a power density¹ of up to 187 Wp/m² and optimised module rear ventilation.



Optimal use of the roof area

The compact design and 10° elevation angle enables a roof area utilisation of up to 82%. Unobstructed roof drainage in accordance with DIN 1986-100 is ensured.



Simple click system

Quick and easy installation thanks to non-interchangeable click connections, measurement-free assembly and re-releasable connections. Length expansion effects are minimised.



Ideal cable routing

Q.FLAT-G6 enables separate installation of DC +/- (separation distances +150 mm). Easy cable management thanks to 3-fold edge clips and integrated cable duct cover.



Minimal ballast

Latest wind tunnel evaluations improve aerodynamics and increase system stability. Optional side covers are available for wind load reduction.



Integrated fall protection

According to DIN EN 795:2012 and CEN/TS 16415:2013 (in progress) certified, circumferential safety rope system is integrated and can optionally be extended by a rope system for max. 3 persons (max. 300 kg).



Maximum safety

Building authority approval Z-14.4-790 (extension applied for), UL 2703 (approval in progress), lightning current carrying capacity according to DIN EN 62561-1 (VDE 0185-561-1):2013-02 (extension applied for)

¹ When using Q.PEAK DUO ML-G9 395 Wp solar modules.

The ideal solution for:



Commercial and industrial rooftop arrays

■ TECHNICAL SPECIFICATIONS

Description	Q.FLAT-G6 EW	Q.FLAT-G6 S
Application	Flat roof with foil, bitumen, gravel, greenery, sheet metal, concrete, open spaces	
Alignment	East-West	South
Inclination	[°]	10
Approved Q CELLS solar modules	Q.PEAK DUO BLK-G9.X, Q.PEAK DUO ML-G9.X, Q.PEAK DUO XL-G9.X, Q.PEAK DUO-G10.X, Q.PEAK DUO ML-G10.X, Q.PEAK DUO XL-G10.X, Q.PEAK DUO M-G11.X, Q.PEAK DUO ML-G11.X, Q.TRON-G1.X+	
Connection	non-penetrating	
Area load	[kg / m ²]	approx. 15 (occupied roof area) approx. 10 (occupied roof area)
Roof pitch	[°]	max. 5
Edge distances	Occupancy of the roof edge and corner areas possible	
System size	[m]	at least 2 double modules / maximum field size 20 × 20 at least 4 modules / maximum field size 20 × 20
Material	Exclusively high-quality aluminium EN-AW-6063-T3 and stainless steel A2-70. No galvanised components or plastics are used.	
Protection mat	11mm thick high-tech protective mat with anti-slip coating for maximum protection against softer migration and roof membrane damage is already pre-assembled on the system.	
Certificates	Lightning current carrying system according to DIN EN 62561 (VDE 0185-561-1):2013-02 General building authority approval Z-14.4-790 for the aerodynamic flat roof system Testing according to UL2703 for the American market	

■ MECHANICAL SPECIFICATIONS

Q.FLAT-G6 EW

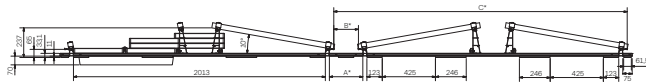

Q.FLAT-G6 S

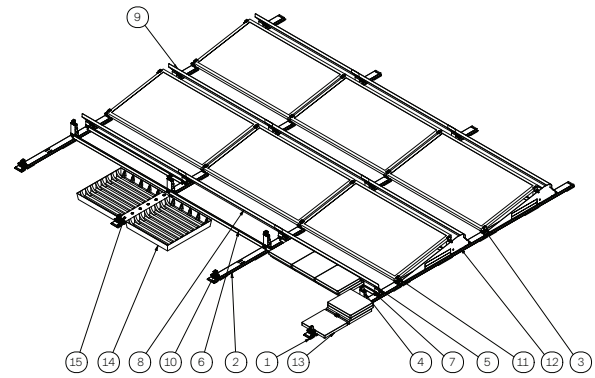
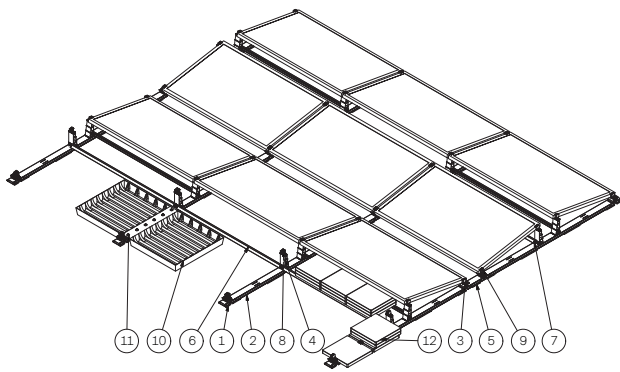
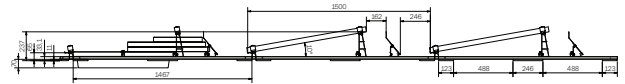

No.	Number	Component	SAP no.	No.	Number	Component	SAP no.
1	8	Q.FLAT-G6 Floor Profile AEBP TYPE 75	20006164	1	4	Q.FLAT-G6 Floor Profile AEBP TYPE 75	20006164
2	8	Q.FLAT-G6 Main Floor Profile HBP Type 2013	20006180	2	12	Q.FLAT-G6 Main Floor Profile HBP Type 1467	20006179
3	8	Q.FLAT-G6 Base B10 M6 Type 75	20006166	3	12	Q.FLAT-G6 Base B10 M6 Type 75	20006166
4	16	Q.FLAT-G6 Tower T10 Type 75	20006167	4	12	Q.FLAT-G6 Tower T10 Type 75	20006167
5	4	Q.FLAT-G6 Connection Profile V2BP Type 267*	20006165	5	12	Q.FLAT-G6 Back Panel Tower RWT10 Type 75	20006168
6	10	Q.FLAT-G6 Ballast Strut QBS TYPE 1840 or Q.FLAT-G6 Ballast Strut QBS TYPE 1740 or Q.FLAT-G6 Ballast Strut QBS TYPE 1682	20006169 20006205 20006230	6	13	Q.FLAT-G6 Ballast Strut QBS TYPE 1840 or Q.FLAT-G6 Ballast Strut QBS TYPE 1740 or Q.FLAT-G6 Ballast Strut QBS TYPE 1682	20006169 20006205 20006230
7	20	Q.FLAT-G6 Screw Ballast S Type M8×30	20006175	7	26	Q.FLAT-G6 Screw Ballast S Type M8×30	20006175
8	16	Q.FLAT-G6 Middle Clamp MK Type 40	20006160	8	9	Q.FLAT-G6 Backside RW10 Type 1800 or Q.FLAT-G6 Backside RW10 Type 1900	20006250 20006177
9	16	Q.FLAT-G6 End Clamp EK TYPE 35	20006162	9	24	Q.FLAT-G6 Screw Side S Type M8×16	20006176
10/11	6	Ballast Trough (on request)		10	13	Q.FLAT-G6 Middle Clamp MK Type 40	20006160
12	13	Ballast Stone 40×40×4 mm (not included in the scope of delivery)		11	12	Q.FLAT-G6 End Clamp EK TYPE 35	20006162
*A 127/B 17.6/C 2205; A 267/B 157.6/C 2345; A 367/B 257.6/C 2445 (please see drawing)				12	3+3	Q.FLAT-G6 Side Cover Left SDL S 10 Q.FLAT-G6 Side Cover Right SDR S 10	20006225 20006227
				13	13	Ballast Stone 40×40×4 mm (not included in the scope of delivery)	
				14/15	6	Ballast Trough (on request)	